

# LOGLIFT 140Z / 150Z



BASIC DATA

# LOGLIFT 140Z / 150Z BASIC DATA

Technical data	F140Z 80	F140Z 95	F150Z 80	F150Z 95
Max. lifting capacity (kNm)	136	127	138	129
Hydraulic outreach (m)	8.00	9.49	8.00	9.49
Hydraulic boom extension (m)	1	2	1	2
Outreach – lifting capacity, standard (m – kg)	3.0 - 3750	3.0 - 3450	3.0 - 4100	3.0 - 3900
	4.0 - 3050	4.0 - 2800	4.0 - 3200	4.0 - 3000
	5.0 - 2600	5.0 - 2400	5.0 - 2650	5.0 - 2500
	6.0 - 2280	6.0 - 2120	6.0 - 2300	6.0 - 2160
	7.0 - 1940	7.0 - 1820	7.0 - 1960	7.0 - 1840
	7.5 - 1800	8.0 - 1560	7.5 - 1820	8.0 - 1580
		9.0 - 1240	9.0 - 1260	
Slewing system	Double			
Slewing angle (°)	425			
Slewing torque, gross (kNm)	28.6			
Max. working pressure (MPa)	26			
Recommended oil flow – fixed pump (l/min), 1-pump	70-90			
Recommended oil flow – fixed pump (l/min), 2-pump	2 × 60-80			
Weight - High seat crane with standard stabilizer equipment (kg)*	2160	2330	2280	2450
Weight - HiVision crane with Standard stabilizer (kg)**	2290	2460	2410	2580
Weight, Cabin crane with Standard stabilizer (kg)*	2570	2740	2690	2860

\*Weight with fixed pump system, oil weight included

\*\* Weight with variable pump system, oil weight included

This table shows a few examples of models, and represents some of all options available. With the opportunity to configure your crane, we can provide you with a crane perfectly tailored to your needs. Please contact your local dealer for more information on the variety of options we can offer.

Side view

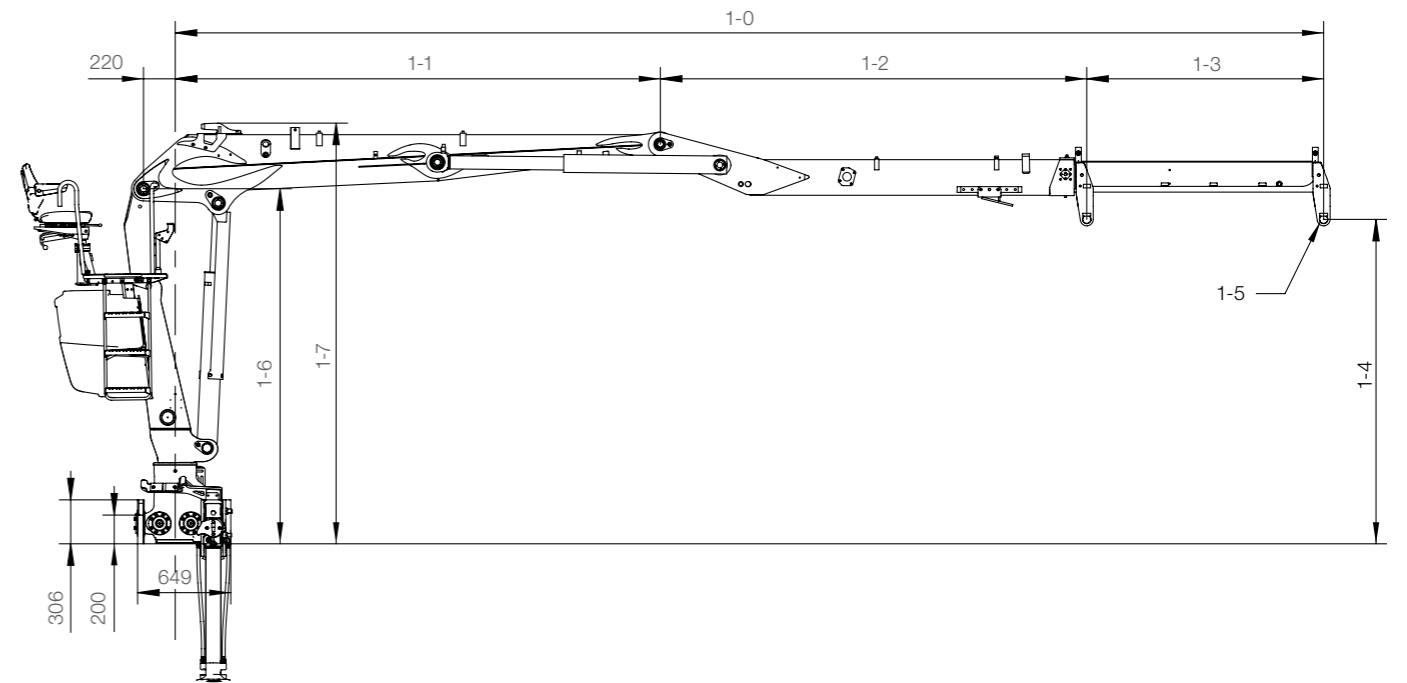

Model	1-0 min	1-0 max	1-1	1-2	1-3	1-4	1-5	1-6	1-7
140Z 80	6350	8000	3380	2970	1650	2259	∅ 40, B=184	2473	2930
140Z 95	6550	9490	3380	3170	2940	2199	∅ 40, B=184	2473	2930
150Z 80	6350	8000	3380	2970	1650	2295	∅ 40, B=184	2508	2965
150Z 95	6550	9490	3380	3170	2940	2235	∅ 40, B=184	2508	2965

All measurements in mm

For more information,  
please visit us at [www.hiab.com](http://www.hiab.com)



# BUILT TO PERFORM

Hiab is the world's leading provider of on-road load handling equipment. Customer satisfaction is the first priority for us. Hiab's product range includes HIAB loader cranes, JONSERED recycling and forestry cranes, LOGLIFT forestry cranes, MOFFETT truck mounted forklifts and MULTILIFT demountables, as well as DEL, WALTCO and ZEPRO tail lifts.

[hiab.com](http://hiab.com)

Hiab is part of Cargotec.

[cargotec.com](http://cargotec.com)

**Disclaimer.** We reserve the right to make changes. Illustrations, drawings and data are not always in accordance with the latest version or standard model in production. The models in the pictures may present special equipment or colours.